



ACCUSERV

Arby's®

Accuserv / ARBY's Switchgear Program Details

Accuserv and Inspire Brands have partnered to provide switchgear solutions for your development needs. The newly created program is specifically designed to reduce lead times on switchgear, control costs, and standardize gear packages.

ARBY's Prototypical Configuration

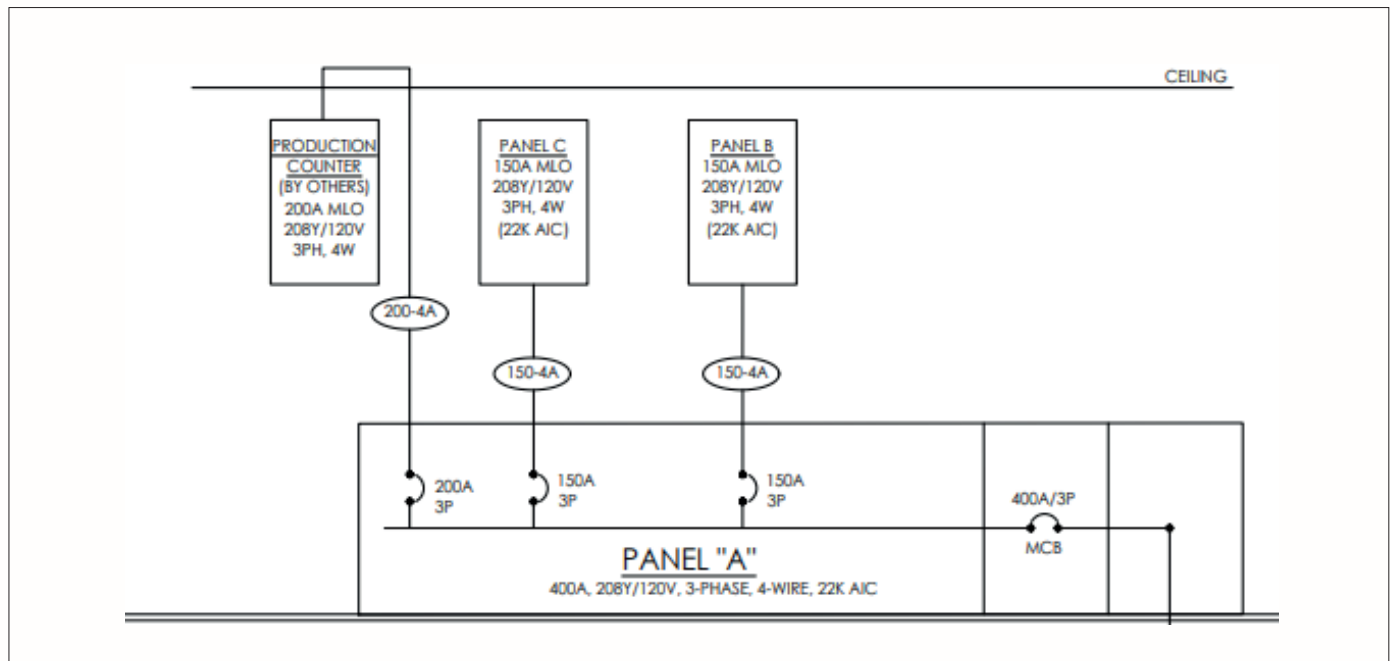

Program Details

Request pricing by posting your construction plan sets to: accu-serv.com/inspirebrands

- Quotes will be returned within 5-10 business days
- ARBY's Prototypical Switchgear System is estimated to have a 20-week lead time (this can change) from date of deposit
- 50% deposit required at time of order (terms can apply)

Contact

Mike Thomas, mthomas@accu-serv.com, Office: 502-400-8677, Mobile: 502-356-4075, accu-serv.com

Arby's®